

THIS DRAWING IS UNPUBLISHED. RELEASED FOR PUBLICATION
 © COPYRIGHT - By - ALL RIGHTS RESERVED.

| LOC | DIST | REVISIONS | | | | | |
|-----|------|-----------|-----|---------------------------|---------|-----|------|
| G | 14 | P | LTR | DESCRIPTION | DATE | DWN | APVD |
| | | P1 | | REVISED PER ECO-11-004917 | 11MAR11 | RK | HMR |

| | | |
|--------------------------------|--------------------------------|--------------------------------|
| AMP WIRE RANGE | Listed FILE E13288 | LR7189 Certified |
| 22-16 AWG SOLID OR STRANDED | 22-16 AWG SOLID OR STRANDED | 22-16 AWG SOLID OR STRANDED |

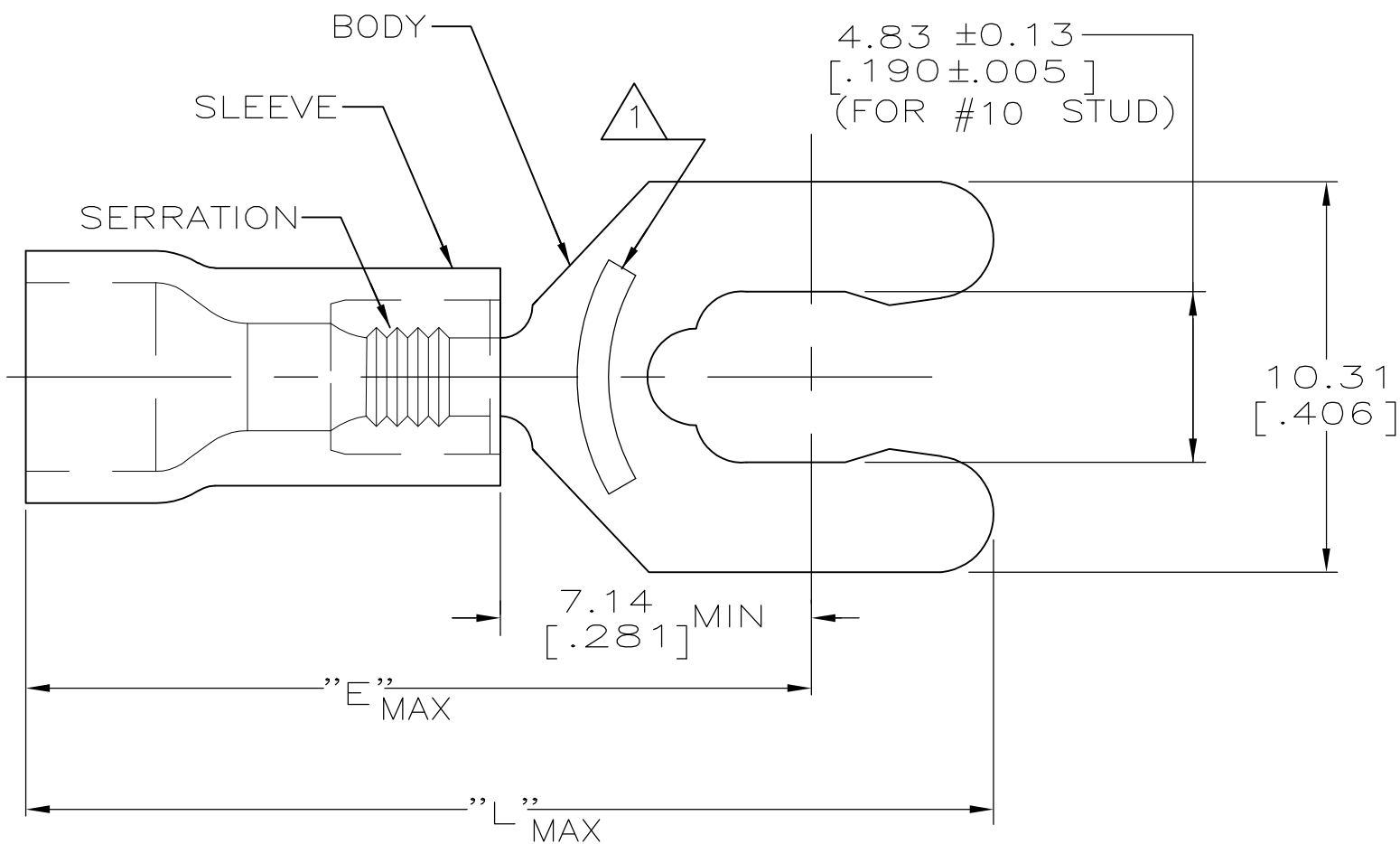

- ① STAMP 10S AMP 22-18* APPROX AS SHOWN
22-16 TERMINALS ARE STAMPED 22-18 IN
ACCORDANCE WITH MILITARY SPEC MIL-T-7928
COMMERCIAL WIRE RANGE IS 22-16
- 2. SEE TABLE FOR WIRE INSUL DIA
- 3. TONGUE MATL THK, 0.79±0.05 [.031±.002]
- ④ MATERIAL: BODY - BRASS PER ASTM B36
SLEEVE - PVC, COLOR - RED

| | | | | | |
|-----------------|-----------------|--------------------------|------|------------------|-----------|
| 23.37 [.920] | 17.70 [.697] | 2.67-3.56 [.105-.140] | 100 | LOOSE PIECE, BOX | 8-52951-1 |
| 24.61 [.969] | 18.95 [.746] | 3.81-5.08 [.150-.200] | 2500 | ON TAPE, REEL | 52951-3 |
| 23.37 [.920] | 17.70 [.697] | 2.67-3.56 [.105-.140] | 5000 | ON TAPE, REEL | 52951-1 |
| 23.37 [.920] | 17.70 [.697] | 2.67-3.56 [.105-.140] | 1000 | LOOSE PIECE | 52951 |
| L | E | WIRE INSUL DIA | QTY | PACKAGE TYPE | PART NO |

| | | | | | | | | | |
|--|--|---|--|---|----------------------------|-------------------------|--------------------|-----------------------|--------------------|
| AMP INCORPORATED CUSTOMER SERVICE SYSTEMS | | MAX RECOMMENDED OPERATING TEMPERATURE: 105°C [221°F] | THIS DRAWING IS A CONTROLLED DOCUMENT. | | DWN L OLMEDA 26JUN95 | TE Connectivity | | | |
| FOR ADDITIONAL PRODUCT INFORMATION OR COPIES OF DRAWINGS AND TECHNICAL DOCUMENTS | PRODUCT INFORMATION CENTER 1-800-522-6752 | VOLTAGE RATING: 600V MAX (1000V FIXTURE OR SIGN) | DIMENSIONS: mm[INCHES] | TOLERANCES UNLESS OTHERWISE SPECIFIED: | CHK M ELLIS 26JUN95 | | | NAME | |
| FOR APPLICATION TOOLING INFORMATION | TOOLING ASSISTANCE CENTER 1-800-722-1111 | CIRCULAR MIL AREA: 0.26-1.65mm² [509-3260] SOLID OR STRANDED | | 0 PLC ± - 1 PLC ± - 2 PLC ± 0.20 [.008] 3 PLC ± - 4 PLC ± - ANGLES ± - | APVD G NGO 26JUN95 | PRODUCT SPEC UL 486A | | | |
| FOR ORDER ENTRY | 1-800-526-5142 | THIS DRAWING IS A CONTROLLED DOCUMENT FOR AMP INCORPORATED. IT IS SUBJECT TO CHANGE AND THE CONTROLLING ENGINEERING ORGANIZATION SHOULD BE CONTACTED FOR THE LATEST REVISION. | MATERIAL ④ | FINISH TIN PER ASTM B545 | APPLICATION SPEC - | SIZE A3 | CAGE CODE 00779 | DRAWING NO C-52951 | RESTRICTED TO - |
| | | | CUSTOMER DRAWING | | WEIGHT - | SCALE 6:1 | SHEET 1 OF 1 | REV P1 | |